



PTE45

Power Pallet Truck

Low cost motorized pallet truck, ideal for crowded loading docks, work cells and congested aisles.



CAPACITY

4500 lbs.

BATTERY

24-volt industrial battery or battery pack. Minimum battery weight 480 lbs. AH capacity minimum/maximum 135/255. Battery compartment dimensions are 29.25" x 8.75" x 29" tall. Connector is SB-175 Gray.

SPEED

Curtis SepEx™ transistor travel control

Variable from 0 mph to 3.66 mph empty

Variable from 0 mph to 2.86 mph loaded

WEIGHT

940 lbs Chassis Only

TIRES

DRIVE

10.5" x 5" rubber

LOAD

3.15" x 4.75" polyurethane

HYDRAULICS

Lift cylinder is hard chrome. Pump unit including motor, gear pump, and solenoid are actuated using a pressure compensated lowering valves mounted high in the power compartment for ease of service.

ELECTRICAL

Curtis SepEx™ transistor travel controller and separately excited Class H drive motor provide high torque throughout entire drive range. Travel speed remains constant relative to throttle position regardless of load on truck. No directional contactors. Master contactor operates with main on/off switch. Automatic resetting circuit breaker and fused circuit protection complete the 24V electrical system.

BRAKES

Drum brake is mounted on motor armature shaft multiplying the braking power through the double reduction transmission. Brake is applied when control arm is within 12.5" of vertical or 28.7" from horizontal handle position.

CONTROLS

Travel, lift, lower functions are located in the ergonomic operator handle, designed to allow operation with either hand. Wrap around guard, reversing switch, thumb control, and horn are standard.

TRANSMISSION

Horizontally mounted drive motor is direct mounted to gear housing. Oil bathed double reduction helical end spur gear drive train transfers power to axle. Time proven basic design allows for long life and ease of maintenance.

BEARINGS

DRIVE WHEEL-Tapered roller bearings sealed in oil bath

LOAD WHEELS-Sealed ball bearings

TRANSMISSION-MOUNT-Vertical thrust and horizontal tapered load bearings—HD

FORK LINKAGE-Self lubricated heat treated bushing no lubrication needed.

ACCESSIBILITY

Removal of one piece power head cover exposes major components for inspection and maintenance. Drive tire can be removed with one nut.

STANDARD EQUIPMENT

- *Curtis* Transistor Travel Controller
- Thumb Control
- Key Switch
- Horn
- Hour Meter BDI Combo Gauge
- Reversing Switch
- Pallet Entry & Exit Wheels

OPTIONAL EQUIPMENT

- Fork Lengths and Fork Widths
- Load Backrest
- Spring Loaded Stability Casters
- (2)12V 135AH Maintenance Free Battery Pack with Built-In 110VAC Charger
- (4)6V 180AH Maintenance Free Battery Pack with Built-In 110VAC Charger
- (1)24V 255AH Industrial Battery



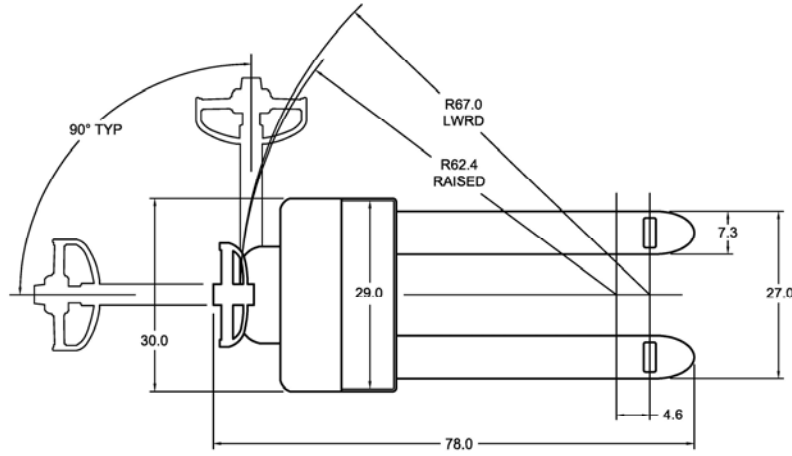

Pallet Width	Pallet Length					
	36		42		48	
	A	B	A	B	A	B
36	62	38	67	52	73	55
40	62	42	68	54	72	57
42	62	44	68	58	73	58
48	63	50	68	58	74	62
60	64	50	69	69	75	72

Note: Data shown in inches.
Dimensions shown are zero clearance. Add 6-12" for maneuvering.

A - Right Angle Stack
B - Intersecting Aisle

