



# S30/35

## Power Drive Straddle Trucks

A short turning radius make it an excellent choice for narrow aisles, storage rooms, or street level loading areas.



### CAPACITY

3000 lbs. to 3500 lbs. at 24" load center

### BATTERY

24-volt industrial battery. Minimum battery weight 490 lbs. Amp hour capacity 195. Battery compartment dimensions are: 31" x 10" x 21" tall, no cover. Connector is 175 Gray—A22

### CHARGER

External automatic smart charger. Input: 40A 120VAC-1Ø-60hz.

### PERFORMANCE

Curtis SepEx® transistor travel control. Gradeability 12% - loaded.

### TRAVEL

Variable from 0 mph to 3.5 mph empty  
Variable from 0 mph to 3.0 mph loaded

### LIFT

Up to 34 fpm empty.  
Up to 24 fpm loaded—2000 lbs

### LOWERING

Up to 28 fpm empty.  
Up to 56 fpm loaded—2000 lbs

### CHASSIS WEIGHT

3129 lbs with battery

### WHEELS

DRIVE WHEEL  
10" x 3" rubber

STABILITY WHEELS  
6" x 2" rubber

TANDEM LOAD WHEELS  
3.5" x 2.75" polyurethane

### CONTROL HANDLE

Protective wraparound hand guard, horn, "Belly Button" reversing switch, thumb travel control are all standard. Handle mounted lift/lower buttons allow uncomplicated and precise load placement. Braking at top and bottom of the handle working range.

### HYDRAULICS

Premium design side mounted mast lift cylinders provides smooth lifting. Full system filtration prevents contaminants from entering the hydraulic system. 24V 3.0kw lift pump motor is designed for peak efficiency at lifting torque.

### ELECTRICAL

Curtis SepEx® transistor travel controller provides infinitely variable travel speeds with efficient use of battery power. Control circuits are fuse-protected with auto reset circuit breaker; plug-in type connectors.

### DRIVE UNIT AND BRAKES

Compact 24V 1.35kw drive motor provides ample torque at low current and temperature levels.

Regenerative "neutral braking" allows for controlled downhill travel while reducing heat build-up extending motor brush life. Drive motor, transmission, electric brake and drive wheel are positively coupled to the control arm, providing operator direct control of all drive functions.

The entire drive system is mounted within the truck frame for maximum protection. Offset drive wheel with stability caster assembly allow for easy steering.

### FRAME AND MAST

Adjustable straddle legs allow for preset outrigger dimensions for various sized pallets:

Inside Dimension (ID): 38", 44", 50"  
Outside Dimension (ID): 46", 52", 58"

Wire mesh safety screen, 47" tall load back rest. Class II ITA fork carriage. Forks are adjustable: 8" ID to 31" OD

High visibility mast design nested two stage I-beam construction with lift cylinders positioned in outer I-beam for best view through mast.

### SERVICEABILITY

Removable two piece power head cover exposes major components for inspection and service. Battery compartment includes flip top cover, removable side panels, and battery compartment rollers for ease of maintenance.

### STANDARD EQUIPMENT

- Adjustable straddle legs
- Battery discharge indicator (BDI)
- Key switch
- Hour meter
- Industrial battery
- ITA Class II fork carriage
- Load backrest (LBR) 47" tall
- Lift lock out
- Remote lift/lower buttons in handle



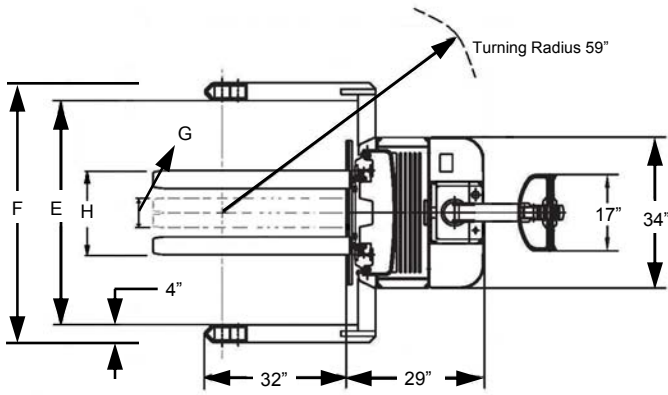

### Right Angle Stacking Aisle Width

Load Length	Load Width			
	36"	40"	42"	48"
36"	70"	71"	72"	74"
42"	70"	71"	72"	74"
48"	70"	71"	72"	74"

- Aisle dimensions listed have zero clearance
- Add 12" for ease of use

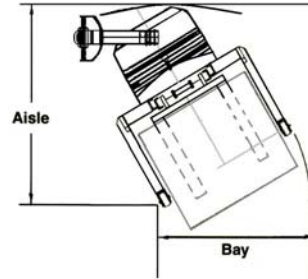

Note: Aisle dimensions listed assume the bay width to be straddle OD plus 2" (1" on each either side of straddle leg).

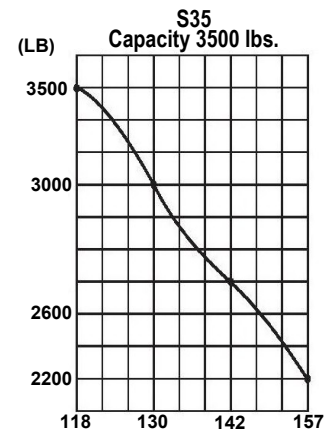
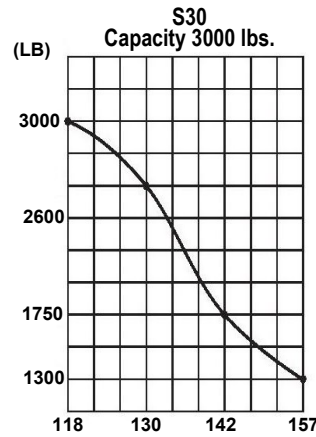
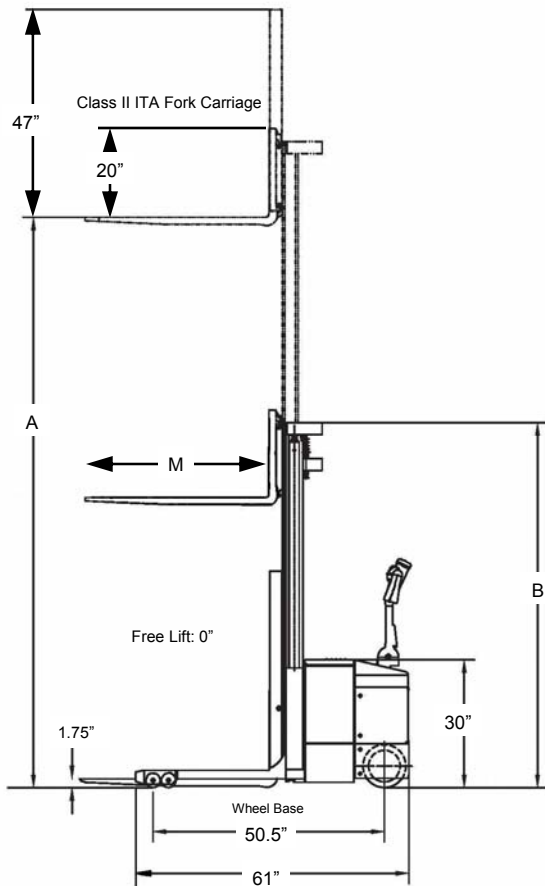

Model #	Lift Height A	Col Height B	Ext Height C	Adjustable Straddle Legs			ITA Class II Fork Carriage				Ship Weight with Battery & Charger
				Length <sup>2</sup>	ID E	OD F	ID G	OD H	Length	Width	
<b>3000 Capacity @ 24" Load Center, Telescopic Mast</b>											
S30-130	130	83.0	176	32	38, 44, 50	46, 52, 58	8	31	36, 42, 48	4	2966
S30-142	142	92.0	189	32	38, 44, 50	46, 52, 58	8	31	36, 42, 48	4	3049
S30-177 Triple	177	82.0	224	32	38, 44, 50	46, 52, 58	8	31	36, 42, 48	4	3318
<b>3500 Capacity @ 24" Load Center, Telescopic Mast</b>											
S35-130	130	83.0	176	32	38, 44, 50	46, 52, 58	8	31	36, 42, 48	4	3006
S35-142	142	92.0	189	32	38, 44, 50	46, 52, 58	8	31	36, 42, 48	4	3089
S35-157 Triple	177	82.0	224	32	38, 44, 50	46, 52, 58	8	31	36, 42, 48	4	3418

<sup>2</sup>Face of fork to center of first load wheel