



# PDS

## Power Drive Straddle Trucks

Short turning radius make it an excellent choice for narrow aisles, tool rooms or street level loading



### CAPACITY

2000 to 2500 lbs.

### BATTERY

24-volt industrial battery or battery pack. Minimum battery weight 480/590 lbs. AH capacity minimum/maximum 180/255. Open battery compartment with rollers, dimensions are 26.37" x 9.06" x open. Connector is SB-175 Gray—A-11.

### SPEED

ZAPI AC O travel controller

### TRAVEL

Variable from 0 mph to 3.4 mph empty  
Variable from 0 mph to 3.1 mph loaded

### LIFT

Up to 33 fpm empty.  
Up to 25 fpm loaded—2000/2500lbs

### LOWERING

Up to 29 fpm empty.  
Up to 57 fpm loaded—2000/2500 lbs

### WEIGHT

1601 lbs Chassis Only

### TIRES

DRIVE  
9" x 3" polyurethane  
LOAD  
4" x 2.75" polyurethane

### HYDRAULICS

Lift cylinder is hard chrome. Pump unit including motor, gear pump, and solenoid. Actuated using a pressure compensated lowering valves regulates lowering speeds.

### ELECTRICAL

ZAPI AC travel controller and AC drive motor provide high torque throughout entire drive range. Regenerative braking and brushless design drastically reduced maintenance.

Travel speed remains constant relative to throttle position regardless of load on truck. Automatic resetting circuit breaker and one piece micro switch design complete the system.

### BRAKES

Electromagnetic brake is mounted on motor armature shaft multiplying the braking power through the ZF GK10 transmission. Brake is applied when control arm is in the vertical or horizontal handle position.

Reduced travel speed when forks are above 12" fork height. Neutral braking-anti-roll back on ramps.

### CONTROLS

Travel, lift, lower functions are located in the ergonomic operator handle, designed to allow operation with either hand. Wrap around guard, reversing switch, thumb control, and horn are standard.

Creep speed function while steer handle is at 1.5° back-tilt from vertical. This allows for easy maneuvering at reduced travel speeds in tight places.

### TRANSMISSION

Vertically mounted drive motor is direct mounted to gear housing. Oil bathed ZF GK10 hypoid bevel gear drive-train transfers power to axle. State of the art optimized gear technology supplies advantages such as minimal envelope circle, zero maintenance, low noise level, high efficiency and high performance.

### FRAME AND MAST

Bolt-on high visibility mast, I-beam construction, lift cylinders positioned in outer I-beam for best view through mast. Dual lifting chains.

Three inch wide adjustable straddle legs allow ease of use in racked aisles. Straddle leg inside dimension (ID) can be set at 38" to 50" in 2" increments .

OUTRIGGER PRESETS:  
ID: 38", 40", 42", 44", 46", 50"  
OD: 44", 46", 48", 50", 52", 56"

Plexiglas safety screen, 36" tall load back rest. Class II ITA fork carriage. Forks are adjustable: 8" ID to 24" OD

### BEARINGS

DRIVE WHEEL-Tapered roller bearings sealed in oil bath  
LOAD WHEELS-Sealed ball bearings

### ACCESSIBILITY

Removal of two piece power head cover exposes major components for inspection and maintenance. Press on drive tire can be removed with one nut.

### STANDARD EQUIPMENT

- 3" Wide Straddle Leg
- Regenerative Neutral Braking
- Creep Speed Control
- Gas Assist Spring Handle
- Plexiglas Mast Guard
- Press-on Polyurethane Drive Tire
- Low Battery – Lift Interrupt
- Hour Meter BDI Combo Gauge
- Key Switch



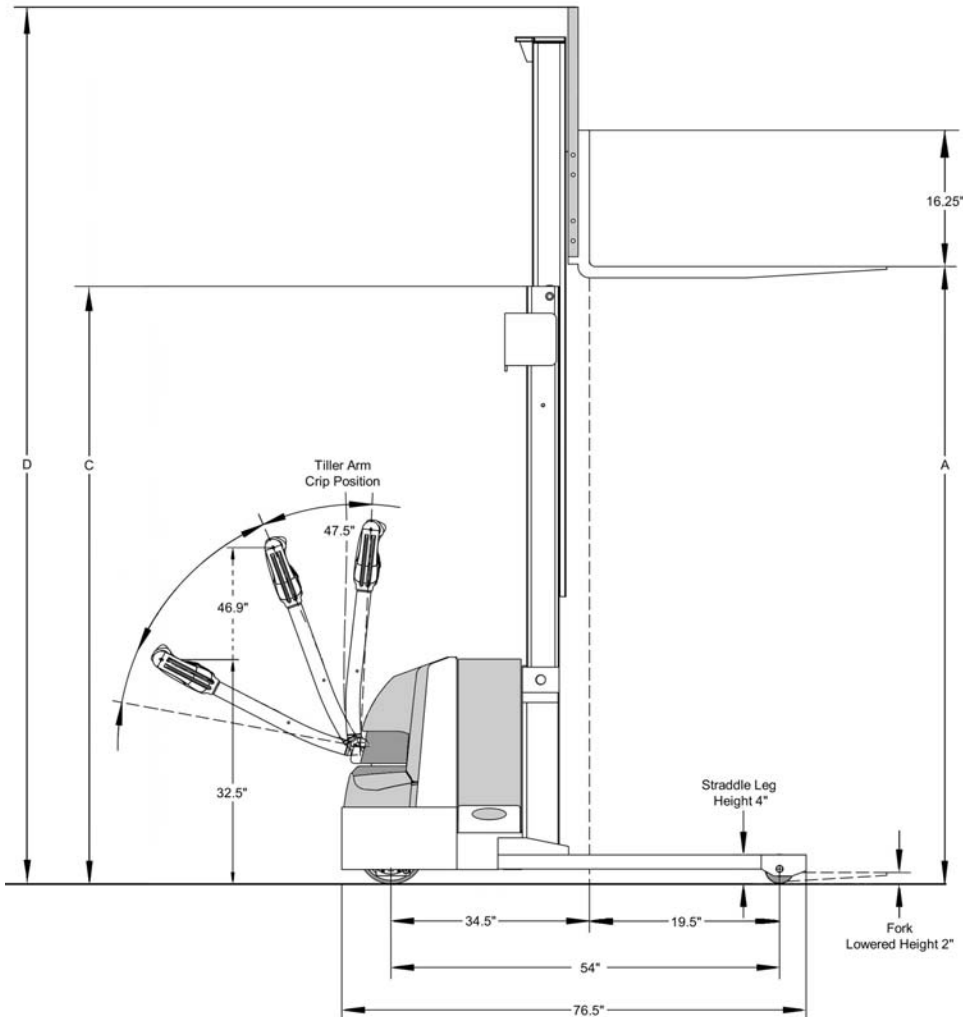

### Right Angle Stacking Aisle Dimensions

Load Length	Load Width			
	36"	40"	42"	48"
36"	66"	66"	68"	69"
42"	66"	66"	68"	69"
48"	80"	80"	79"	77"

- Aisle dimensions listed have zero clearance
- Add 12" for ease of use

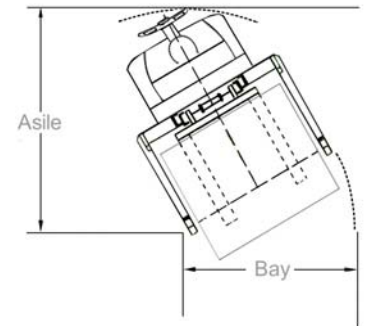

Note: Aisle dimensions listed above assume the bay width to be straddle OD plus 2" (1" on each either side of straddle leg). Straddle OD is the load width plus 8"

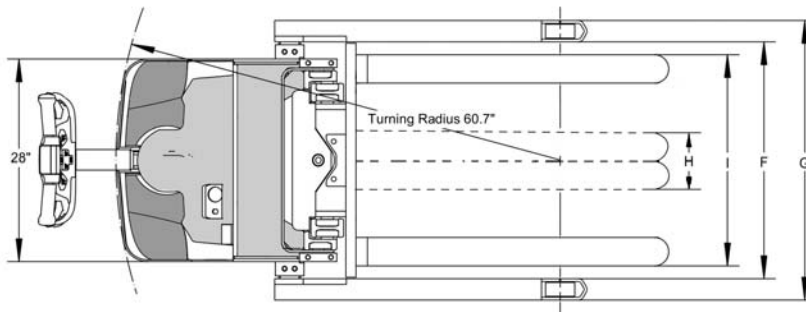

Model #	Lift Height	Col Height	Free Lift	Ext Height w/LBR	Adj Straddle Leg 2" Increments		Forks		Ship Weight w/o BAT
	A	C		D	ID	OD	H	I	
	2000 Capacity @ 24" Load Center ITA Class II Fork Carriage								
PDS 20-106	106	71	6	142	38 to 50	44 to 56	8	24	1135
PDS 20-130	130	83	6	165	38 to 50	44 to 56	8	24	1170
PDS 20-142	142	95	6	178	38 to 50	44 to 56	8	24	1195
PDS 20-157	157	71	50	193	38 to 50	44 to 56	8	24	1395
2500 Capacity @ 24" Load Center ITA Class II Fork Carriage									
PDS 25-106	106	71	6	142	38 to 50	44 to 56	8	24	1351
PDS 25-130	130	83	6	165	38 to 50	44 to 56	8	24	1376
PDS 25-142	142	95	6	178	38 to 50	44 to 56	8	24	1401
PDS 25-157	157	71	50	193	38 to 50	44 to 56	8	24	1601

- ZAPI travel control
- ZF GK10 Drive
- Neutral braking
- Creep speed control
- Gas assist spring handle
- Steel wrap around bumper
- 3" wide adjustable straddle legs
- Low battery lift-interrupt
- Hour meter BDI combo gauge